



15 – MARCH - 2020

Name of the event	NCR DELHI AUTOX - 2020
Start Date of the event	15/03/2020
End Date of the event	15/03/2020
Status of the event	OPEN
Category	4W
Name of the Organizer	THAR MOTORSPORT
Address	87, SECOND FLOOR, GOPALBARI, AJMER ROAD, JAIPUR
Phone	+91-141-4044999 / +91-9828222999
Email	tharmotorsport@gmail.com / info@tharmotorsport.co.in
Website	www.tharmotorsport.co.in

SUPPLEMENTARY REGULATIONS

Approved by



The Federation of Motor Sports Clubs of India

WARNING

MOTORSPORT CAN BE DANGEROUS. DESPITE ORGANIZERS TAKING ALL POSSIBLE PRECAUTIONS UNAVOIDABLE ACCIDENTS MAY HAPPEN. YOU ARE PRESENT HERE AT YOUR OWN RISK.

TABLE OF CONTENTS

1. INTRODUCTION	4
2. ORGANIZATION	4
3. PROGRAMME	6
4. ENTRIES	6
5. INSURANCE	7
6. ADVERTISEMENT AND IDENTIFICATION	8
7. ADMINISTRATIVE CHECKS	8
8. PRE-EVENT SCRUTINEERING, SEALING AND MARKING	9
9. IDENTIFICATION OF OFFICIALS	9
10. PRIZES	9
11. PROTEST & APPEAL	9
12. RUNNING OF THE EVENT	10
13. PENALTIES	11
14. SAFETY REQUIREMENTS	12
NAMES AND PHOTOGRAPHS OF CRO'S	15

1. Introduction

1. The NCR Delhi AutoX 2020 is run in compliance with the 2020 International Sporting Code of the Federation Internationale de l' Automobile (FIA), 2020 FMSCI General Prescriptions for Autocross, the relevant Technical Regulations and these Supplementary Regulations (SRs).

The Federation of Motor Sports Clubs of India (FMSCI) is the National Sporting Authority (ASN) of FIA in India.

Modifications, amendments and / or changes to these SRs will be announced only by numbered and dated bulletins, issued by the organizers, approved by the FMSCI or Stewards.

2. Acquaintance with and submission to Rules
Every person, or group of persons, organising a competition or taking part therein
 - Shall be deemed to be acquainted with all the relevant rules and regulations of the FMSCI
 - All competitors must sign the indemnity and declaration form, which are enclosed with the Entry Form
 - These are conditions precedent attached to the submission of entries and taking part in an event and all competitors participating shall be bound by them and also the rules and regulations hereinafter set out or amendments made thereto.
 - Shall undertake to submit themselves without reserve to the above and to the decision and consequences resulting therefrom.

2. Organization

2.1 FMSCI Permit No./s: 45/2020 – Dtd. 06/03/2020

2.2 Organizers name, address and contact details

ORGANIZER – THAR MOTORSPORT

ADDRESS – 87, SECOND FLOOR, GOPALBARI, AJMER ROAD, JAIPUR

PHONE - +91-141-4044999 / +91-9828222999

E-mail – tharmotorsport@gmail.com / info@tharmotorsport.co.in

Website – www.tharmotorsport.co.in

2.3 Managing Committee

RAJ SINGH RATHORE	VIKRAMJEET SHARMA	RIHEN BHARDWAJ
YASH SHARMA	BALBIR SINGH RATHORE	DEEPESH RAO
PURVISH BHARDWAJ	SAURABH SHUKLA	SAURABH NANDWANA
SAURABH JAIN	SIDHARTH SINGH	AJAY RAJOTIA

2.4 Organizing Committee

RAJ SINGH RATHORE	VIKRAMJEET SHARMA	RIHEN BHARDWAJ
YASH SHARMA	BALBIR SINGH RATHORE	DEEPESH RAO

2.5 **FMSCI Officials**

Chief Steward	SANDEEP SHARMA
Steward	ALOK MISHRA
Steward	UMESH RAHEJA
Chief Scrutineer	YOGESH RAHEJA

2.6 **Senior Officials**

Clerk of the Course	RAJ SINGH RATHORE
Assistant Clerk of the Course	VIKRAMJEET SHARMA
Secretary of the Meet	BALBIR SINGH RATHORE
Chief Safety Officer	DEEPESH RAO
Chief Medical Officer	SIDHARTH SINGH
Chief Time keeper	DILLIIP ROUT
Competitors Relations Officer	RIHEN BHARDWAJ
Media Relations Officer	PURVISH / SAURABH
Results Co-Ordinator	VGONEXT

2.7 **Location of HQ****From:**

Day	DD/MM/YYYY	Time (hrs.)	Venue
SUNDAY	15/03/2020	0700 hrs.	Off Road Adventure Zone, Gurgaon Faridabad Road, GURGAON

To:

SUNDAY	15/03/2020	2000 hrs.	Off Road Adventure Zone, Gurgaon Faridabad Road, GURGAON
--------	------------	-----------	----------------------------------------------------------

3. Programme

15/03/2020 at Off Road Adventure Zone, Gurgaon Faridabad Road, GURGAON	
Time	Details
0700 hrs	First Steward Meeting
0700 hrs – 1500 hrs	Documents & Vehicle Scrutiny
0700 hrs – 0730 hrs	Track Walk
0745 hrs	Drivers Briefing
0800 hrs – 1900 hrs	Race Runs
1930 hrs	Final Results & Classifications
1930 hrs	Final Steward / Scrutineers Meeting
2000 hrs	Prize Distribution

4. Entries

4.1 Opening and Closing Dates

Entries open with the publication of these Supplementary Regulations
Closing date of all entries: 15/03/2020 @ 1500 hrs.

4.2 Entry Procedure

Those wishing to take part in the event must send the enclosed entry form duly completed to the permanent secretariat address given in Art.2.2 prior to the closing date as mentioned in Art.4.1

4.3 Maximum number of Entries

The maximum number of entries accepted would be no more than 250 Runs. If more entries are than these are received, then the organizers reserve the right to decide which entries would be accepted.

4.4 Groups & Classes & Entry Fees **(PLEASE SELECT YOUR CLASSES FROM THE FORMAT BELOW. IF YOU ARE RUNNING ANY OTHER DIFFERENTLY NAMED CLASSES THEY ARE TO BE LISTED UNDER THE "OTHERS" SECTION WITH CC MENTIONED.)**

ENTRY FEES

The opening and closing date for entries will be as in schedule.

ENTRY FEE

Registration Fee: Rs. 1000/- For first 50 Registrations

Registration Fee: Rs. 1500/- After 50 Registration

Each Race Run Rs. 3,500/- For first 100 Registrations

Each Race Run: Rs. 4,000/- After 100 Registrations

Entry is confirmed only when payment is completed in full.

TEAM ENTRIES

Fee of Rs. 5,000 per club team of minimum 3 and maximum 8 individuals

Fee of Rs. 25,000 per Manufacturer team of minimum 3 and maximum 8 individuals

List of Team Members to be provided at the time of registration. No new members can be added afterwards.

A person who has already taken a race run in the event cannot join any team afterwards.

Entry fees are inclusive of taxes applicable.

4.5 Payment

The entry fees can be either by demand draft in favor of **THAR MOTORSPORT** payable at **JAIPUR** or by cash or by wire transfer.

Name of Bank	AXIS BANK
Branch	VAISHALI NAGAR, JAIPUR
Nature of Account	CURRENT
Account No.	911020059294323
IFSC Code	UTIB0000311

4.6 Refund

Entries fees will be refunded in full only

- To candidates whose entry has not been accepted
- In case of event not taking place

The organizers may refund 50% of the entry fee to those competitors who, for reasons of force-majeure (duly accepted by the organizing committee) were unable to start in the event.

5. Insurance

Organizers holding a valid 2020 FMSCI Permit for an event are covered for

Competitors: A maximum of 250 competitors with valid FMSCI Competition License participating in various events across the Country on a given day are covered for Personal Accident Insurance for Rs. 5 Lakhs with Rs. 5 Lakhs medical expense extension per person.

Officials: A maximum of 100 officials officiating in various events across the Country on a given day are covered for Personal Accident Insurance for Rs.25 lakhs with Rs.1 lakh medical expense extension per person.

THESE INSURANCES ARE ISSUED BY NEW INDIA INSURANCE COMPANY LTD AND VALID DURING THE RUNNING OF THE EVENT ONLY. ORGANIZERS / COMPETITORS ARE ADVISED TO TAKE ANY ADDITIONAL INSURANCES THEY MAY DEEM FIT. IF THEY HAVE MORE THAN 100 OFFICIALS & ALSO REQUIRE DOOR TO DOOR COVERAGE PLEASE CONTACT: S.MANIKANDAN@STENHOUSE.IN

6. Advertisement and Identification

- 6.1 It is compulsory to carry organizers advertisement on the competing vehicles.
- 6.2 Competitors are allowed to affix any kind of advertisements on their vehicle provided that
- Any instructions issued by the organizers are observed.
 - It is authorized by the National laws and FMSCI regulations
 - Advertising must not be of a political, obscene or insulting nature. It must be in good taste and not conflict with the vehicle's official numbers in any way
 - It should not be placed as to prevent recognition by Officials or Marshals.
 - The space designated in Appendix '4' of the General Prescription is left free of advertising other than that provided by the organizers.
 - It does not encroach upon the spaces reserved for rally plates, number plates and windscreen strips,
 - It does not interfere with the driver's vision through the windows.
- 6.3
- The organizers will supply each crew with identification plates comprising: 2 panels carrying the race number termed COMPETITION NUMBERS. They will incorporate the race number, the name of the event and if appropriate the name of the organizers' main sponsor. They will be available as stickers.
 - Competitors taking part in the Championship may elect to keep the same competition number throughout the Championship. In this case, a written request must be made to the organizer and a written acceptance taken.
 - Throughout the duration of the Event, the plates must be affixed in conformity of the supplementary regulations. In no case should they cover, even partially, the vehicle's licence plates.
 - The numbers plates must appear on both sides of the vehicle and be clearly visible during the entire event.
 - At any time during the event, the absence or incorrect positioning of a race number plate may result in a penalty up to a maximum of INR 1,000/-.
 - The competitor will be recognizable by means of an identification tag. It must carry the competitors photograph, name & blood group. Any breach noted by an official will result in a cash penalty up to a maximum of INR 1,000/-.

7. Administrative checks

7.1 Documents Submission

Entrants should produce the following for inspection at the time of submitting the vehicle for pre-event scrutiny and administrative check on the date / time as mentioned in Art.3.

Competitors are required to bring:

- i) Authority letter from owner of the vehicle if the first driver / navigator not the owner of the vehicle used in the Autocross
- ii) FMSCI Competition License for Driver (Minimum 4W Club sport Autocross License. Apply online from <http://licence.fmsci.co.in/>)
- iii) 3 Passport size photographs

Competitors are required to carry all the above documents throughout the event. All the documents shall be valid for the date of the event.

8. Pre-event Scrutineering, Sealing and Marking

8.1 Venue & Timings

Place : Off Road Adventure Zone, Gurgaon Fridabad Road, GURGAON

Date : 05/03/2020

Time : 0700 hrs. – 2000 hrs.

9. Identification of Officials

Safety Marshal	Orange
Safety Officer	Orange with white stripe and text
Post Chief	Blue with white stripe and text
Media	Green
Stage Commander	Red with text
Competitor Relations Officer	Red Jacket or Red Tabard
Medical	White
Radio	Yellow with blue mark
Scrutineer	Black

10. Prizes

Trophies for : -

- > Fastest 3 in each class
- > Overall fastest 3 in 2-wheel drive and 4-wheel drive.

The organizers may at their discretion offer awards in addition to those specified in these Supplementary Regulations.

Distribute the awards, if through unforeseen or special circumstances, the competition is stopped before its scheduled completion.

11. Protest & Appeal

1. LODGING A PROTEST OR APPEAL

All protests and / or appeals must be lodged in accordance with the stipulations of Articles 13,14 and 15 of the Code.

2. PROTEST FEES

For Closed, Closed Invitation and Open Events, the protest fees are ₹7,080/= (Rupees Seven Thousand Eighty Only) (₹6,000/= +₹1080 GST)

If a protest requires the dismantling and re-assembly of a clearly defined part of the car any additional deposit must be specified in the Supplementary Regulations of the event OR will be specified by the Stewards upon a proposal of the FMSCI Technical Delegate / Chief Scrutineer.

If the protest is overruled or it is withdrawn after being brought, no part of the fee shall be returned. (Article 13.10.1 of FIA International Sporting Code)

If it is proved that the author of the protest has acted in bad faith, the FMSCI may inflict upon them one of the penalties laid down in the Code. (Article 13.10.3 of sporting code)

3. APPEALS

₹113,280/= (Rupees One Lakh Thirteen Thousand Two Hundred Eighty Only) (₹96,000/= +₹17,280/= GST)

- Competitors may appeal against decisions, in accordance with the stipulations set out in Articles 15.1 of the Code.
- Competitors have the right to appeal against a sentence or other decisions pronounced on them by the Stewards of the meeting. They must, however under pain of forfeiture of their right to appeal, notify the Stewards of the Meeting in writing within one hour of the publication of the decision, of their intention to appeal.
- The right to bring an appeal expires 96 hours from the moment the stewards are notified of the intention to appeal on condition that the intention of appealing has been notified in writing to the stewards within one hour of the publication of the decision. This ground of appeal may be brought by fax or by any other electronic means of communication with confirmation of receipt. Confirmation by a letter of the same date accompanied by the necessary fee is required. The FMSCI will give its decision within a maximum of 30 days.
- All parties concerned shall be given adequate notice of the hearing of any appeal. They shall be entitled to call witnesses, but their failure to attend the hearing shall not interrupt the course of the proceedings.
- The confirmation of an appeal to the FMSCI must be accompanied by a fee of ₹113,280/= (Rupees One Lakh Thirteen Thousand Two Hundred Eighty Only).
- This fee becomes due from the moment the appellant notifies the Steward of the intention of appealing and remains payable even if the appellant does not follow up the declared intention to appeal.
- If the appeal is rejected or it is withdrawn after being brought, no part of the fee shall be returned.
- If judged partially founded, the fee may be returned in part, and in its entirety if the appeal is upheld.
- If it is proved that the author of the appeal has acted in bad faith, the FMSCI may inflict upon them one of the penalties laid down in the Code.

12. Running of the Event

Scrutiny & Event Venue: Off Road Adventure Zone, Gurgaon Faridabad Road, GURGAON

Track Surface: - Hard Pack Dirt. Distance: - Apx 2 Kms.

Timing: VGONEXT Laser Timing with manual stopwatch as back up

The sequence of competitors to be announced verbally before lineup. Competitors required to report in Report in their allotted sequence and time. Failure to do so will be considered as a DNS for that run for the participant.

Fastest time (added penalties) of the competitor for each track run in the corresponding class added together gives the competitors time for that class. Only the fastest run time in case of multiple

runs in that class of the same competitor to be counted.

Once the race runs are in progress and the start gate is empty with no car in lineup, verbal announcements or text announcements in official competitors' group will be made to the participants and it is their duty to stay informed. If no competition vehicle lines up at the race start for next 10 minutes the organizers reserve the right to consider the remaining race cards of the competitors as forfeited and close the race gates.

No rash, erratic or fast driving allowed near the event area and villages by all in attendance.

Amateur or Newcomers can drive in Pro or Open groups.

A car confirming to stock group can run in the higher mod and open group respective classes.

A car confirming to mod group can run in the higher open group respective classes.

AMATEUR: An Amateur is deemed to be a competitor who has

- Not participated in any Cross-Country Rally, Raid in the Extreme, Speed or Stage category.

Participation in a TSD event is NOT a disqualifier.

- Not qualified for a podium finish in any Autocross/Gymkhana/Sprint event

- The participant would have to declare his Amateur or Pro status in the entry form. However, the determination of the status of participant as Amateur or PRO rests solely with the organisers.

In case of less than 3 entrants in a Class, the organizer reserves the right to merge the class with the next above class.

PROPERTY DAMAGE:

In case of damage to any property during the run OR transport section of villagers including fencing, livestock or any other possessions the damage claim has to be reimbursed fully by the competitor.

Refusal to do so will be reported to FMSCI as unsporting behavior and invite penalties up to Disqualification.

13. Penalties

REASONS	START REFUSED	DISQUALIFY	PENALTY	DNF
Entry Fees not Paid	Yes			
Documentation Incomplete		Yes		
Not carrying advertisements as per Appendix I	Yes			
Inability to produce Race Card at start	Yes			
Late sign-in on qualifying morning				
Scrutineering				
No seat belts		Yes		
Seats Not Fixed Properly		Yes		
Head Lights Not working				
Bad Tires and Brakes		Yes		

Loose items in car	Yes			
Missing Helmet		Yes		
Helmet not strapped properly	Yes			
Driver side Window not closed				
Not wearing gloves				
Late at Start by 5 minutes		Yes		
Over speeding or doing unsafe practice rounds in and around Auto - cross premises/ roads		Yes		
Unsporting Manner		Yes		
Identification Marks		Yes		
Fraud		Yes		
Travel in opposite direction		Yes		
Car unable to start within 60 secs at start line		Yes		
Over speed after stop finish line		Yes		
False Start (up to 2 secs)				
1 st Offense			5 secs	
2 nd Offense			10 secs	
3 rd Offense		Yes		
False start more than 2 secs		Yes		
Knocking down of cone			5 secs	
Breach of track			5 secs	
Leaving track & gaining unfair advantage		Yes		
Unauthorized driver		Yes		
Hitting time control/timing equipment or marshal stations		Yes	Cost of timing equipment as decided	

14. Safety Requirements

DRIVERS SAFETY:

No driver will be allowed to take part in any official practice, qualifying or race unless they have the following:

- Driver should wear suitable clothes; Shorts are not permitted. A Driving Suit is recommended. Driving gloves is compulsory.
- During the event, all drivers participating should wear a Branded BIS (minimum) marked Safety Helmet and shall be properly harnessed in the seat belt. The helmet chin strap should be securely fastened while competing.
- Footwear should be such that shoes covering the entire foot shall be worn.
- All loose items, inside and outside the car, must be removed. Handheld items, such as but not limited to, cameras and cell phones are considered loose items.
- The driver side and left side windows must remain at least three quarters closed during his run. The back-side windows may be left open in rainy conditions.

VEHICLE COMPLIANCE

General Prescriptions 12 of 28

A vehicle will not be allowed to start unless it conforms to the safety requirements detailed below

- Minimum 3-point Seat belts as provided by the manufacturer are mandatory for all classes and of Roll caged vehicles minimum 4-point safety harness
- Tires must be in good condition, with no cord or belts showing or cracks in the tread or sidewall.
- Throttle return action shall be safe and positive.
- No excessive fuel, oil, water or brake fluid leaks should be observed when the engine is running.
- In the modified and unrestricted open class, vehicles which have Bonnets, doors, boot or any other part made of material other than metal are permitted. The front right doors have to be original metal with opening and locking system for safety and easy access. If the car is equipped with a FMSCI/FIA spec roll cage, the material of the passenger door is free. Any other material other than metal on the front right door, the car should compulsorily have a roll cage. Cars which have been fitted with a roll cage cannot remove the same.
- Steering “spinner” knobs shall not be permitted and mechanical components like wheel bearings, shocks, steering and suspension shall be in good operating condition.
- Pedal operation must not be impeded. Driver’s side floor mat must be removed unless securely mounted. OE fasteners designed to prevent the mat from moving forward satisfy this requirement if they are in good working order.
- Wheels must be safely affixed. They shall not be reversed so that the lughole taper does not mate with the chamfer of the lugs. All studs and lug nuts must be present and functional.
- Vehicles must have a means of access on either side of the Passenger compartment which can be operated from inside or outside. Access must be sufficient to remove an occupant without interference from any door locking devices

The above are only indicative. Refer the FMSCI Technical Regulations 2019 for Autocross for more detail.

COMPULSORY EQUIPMENTS FOR ROLL CAGED VEHICLES

- Roll bars / cage complying with FMSCI regulations.
- Rally seats without recliners SFI
- Safety harness SFI (minimum 4 POINT).
- BIS / Snell / SFI Approved Helmets

EVENT SAFETY

SAFETY Ambulance:

Minimum well equipped 1-trauma care ambulance with doctors and one more ambulance to transport the injured to a nearby hospital.

Barricading:

All spectator areas should be well cordoned off. None other than the competitors, pit /service crews and officials shall be present in the pits and other race areas.

Fire Tender & Fire Extinguishers:

A fully equipped fire tender should be present during official practice and races. Adequate number of fire extinguishers should be placed at parc ferme, pits and Marshall Posts at the track. In case a fire – tender is not available; the Stewards can inspect the available number of extinguisher's and give the go ahead if they feel it is adequate.

Communication :

Wireless Communication is a must between officials, post marshals and ambulances.

Security:

Enough security persons should be deployed to control the crowd from entering into the pits and racetrack.

Names and photographs of CRO's

Rihen Bhardwaj

9929266347

info@tharmotorsport.co.in

Will be present at:

- At the Secretariat.
- At the start of the scrutineering.
- Near the "PIT AREA".

NOTES / WAIVERS

GROUP & CLASSES (APPROVED BY AUTOCROSS COMMISSION SUBJECT TO ALL VEHICLES ADHERING TO SAFETY NORMS OF TECHNICAL REGULATIONS OF AUTOCROSS)

A. Amateur- INAC 4

1. 2 WD UP TO 1400 CC
2. 2 WD UP TO 3000 CC
3. 4 WD UP TO 1600 CC
4. 4 WD UP TO 3000 CC

B. PRO STOCK- INAC 3

1. 2 WD UP TO 1400 CC
2. 2 WD UP TO 1600 CC
3. 2 WD UP TO 3000 CC
4. 4 WD UP TO 1400 CC
5. 4 WD UP TO 4000 CC

C. PRO MOD - INAC 2

1. 2 WD UP TO 1100 CC
2. 2 WD UP TO 1400 CC
3. 2 WD UP TO 3000 CC
4. 4 WD UP TO 1400 CC
5. 4 WD UP TO 1600 CC
6. 4 WD UP TO 4000 CC

D. OPEN - INAC 1 Unrestricted 2WD / 4WD

1. SUV
2. THAR / JEEP
3. PICK UP SPORTS TRUCK
4. 2 WD OPEN
5. 4 WD OPEN
6. WOMEN
7. LUXURY OPEN

For Forced Induction vehicles, including O.E. fitments, a factor of 1.5 for diesel and 1.7 for petrol vehicles will be applied to basic engine capacity for determination of group class. A similar factor would be applied for vehicles having gas charge system on board irrespective of the fact that it is used or otherwise.

In case of less than 3 entrants in a Class, the organizer reserves the right to merge the class with the next or above class.

APPENDIX 1: COMPETITION NUMBERS & ADVERTISING

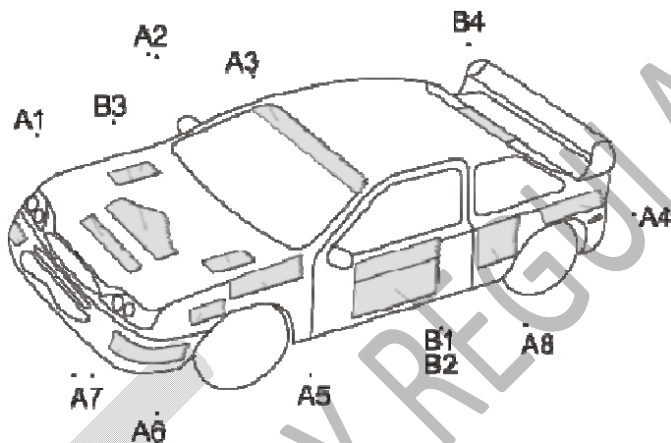

- A1 : TBA
- A2 : Club/Sponsor
- A3 : Sponsor / Organising Club
- A4 : TBA
- A5 : TBA
- A6 : TBA
- A7 : TBA
- B1 : Competition Number

PROTEST FORM

Name of Event		Date	
Organizer		Venue	
Status		Permit No.	

Name of the Competitor	
Competition License No.	
Competition Number in the event	
Reason for Protest	

To: The Chairman of Stewards

<p>Details of Protest</p>

Fees Enclosed			
Signature			
Date		Time	

INTENTION TO APPEAL FORM

Name of Event		Date	
Organizer		Venue	
Status		Permit No.	

Name of the Competitor	
Competition License No.	
Competition Number in the event	
Against Stewards Decision No.	

To: The Chairman of Stewards

I / We hereby file our Intention to Appeal to the Indian Motor Sports Appeal Court against the Stewards Decision No. mentioned above.

Signature			
Date		Time	